

A

B

# TABLE OF DIMENSIONS #150

NOMINAL SIZE	OD FF (INCHES)	OD RING (INCHES)	B.C. (INCHES)	ID (INCHES)	HOLE SIZE (INCHES)	# BOLT HOLES	FF ARMOR	RING ARMOR
1.00	4.25	2.50	3.12	0.69	0.62	4	.06	.06
1.50	5.00	3.25	3.88	1.35	0.62	4	.06	.06
2.00	6.00	4.00	4.75	1.75	0.75	4	.09	.06
2.50	7.00	4.75	5.50	2.09	0.75	4	.09	.09
3.00	7.50	5.25	6.00	2.72	0.75	4	.13	.09
4.00	9.00	6.75	7.50	3.69	0.75	8	.19	.13
6.00	11.00	8.63	9.50	5.72	0.88	8	.19	.13
8.00	13.50	10.88	11.75	7.63	0.88	8	.25	.19
10.00	16.00	13.25	14.25	10.00	1.00	12	.25	.19
12.00	19.00	16.00	17.00	12.00	1.00	12	.25	.25
14.00	21.00	17.63	18.75	14.00	1.12	12	.25	.25
16.00	23.50	20.13	21.25	16.00	1.12	16	.25	.25
18.00	25.00	21.50	22.75	18.00	1.25	20	.25	.25
20.00	27.50	23.75	25.00	20.00	1.25	20	.25	.25
24.00	32.00	28.13	29.50	24.00	1.38	20	.25	.25

# TABLE OF DIMENSIONS #300

NOMINAL SIZE	OD FF (INCHES)	OD RING (INCHES)	B.C. (INCHES)	ID (INCHES)	HOLE SIZE (INCHES)	# BOLT HOLES	FF ARMOR	RING ARMOR
1.00	4.88	2.75	3.50	0.69	.75	4	.06	.06
1.50	6.13	3.63	4.50	1.35	.75	4	.06	.06
2.00	6.50	4.25	5.00	1.75	.75	8	.09	.06
2.50	7.50	5.00	5.88	2.09	.88	8	.09	.09
3.00	8.25	5.75	6.63	2.72	.88	8	.13	.09
4.00	10.00	7.00	7.88	3.69	.88	8	.19	.13
6.00	12.50	9.75	10.63	5.72	.88	12	.19	.13
8.00	15.00	12.00	13.00	7.63	1.00	12	.25	.19
10.00	17.50	14.13	15.25	10.00	1.13	16	.25	.19
12.00	20.50	16.50	17.75	12.00	1.25	16	.25	.25
14.00	23.00	19.00	20.25	14.00	1.25	20	.25	.25
16.00	25.50	21.13	22.50	16.00	1.38	20	.25	.25
18.00	28.00	23.38	24.75	18.00	1.38	24	.25	.25
20.00	30.50	25.63	27.00	20.00	1.38	24	.25	.25
24.00	36.00	30.38	32.00	24.00	1.63	24	.25	.25

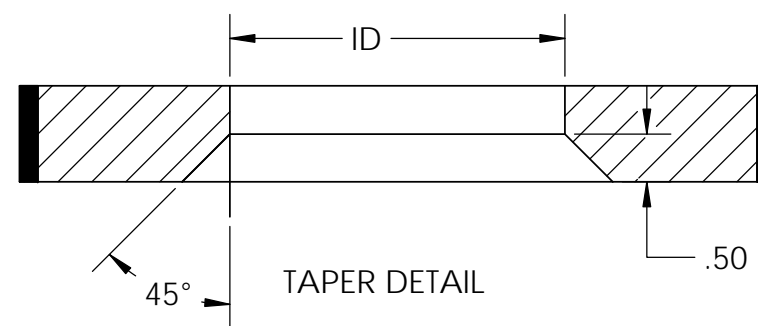
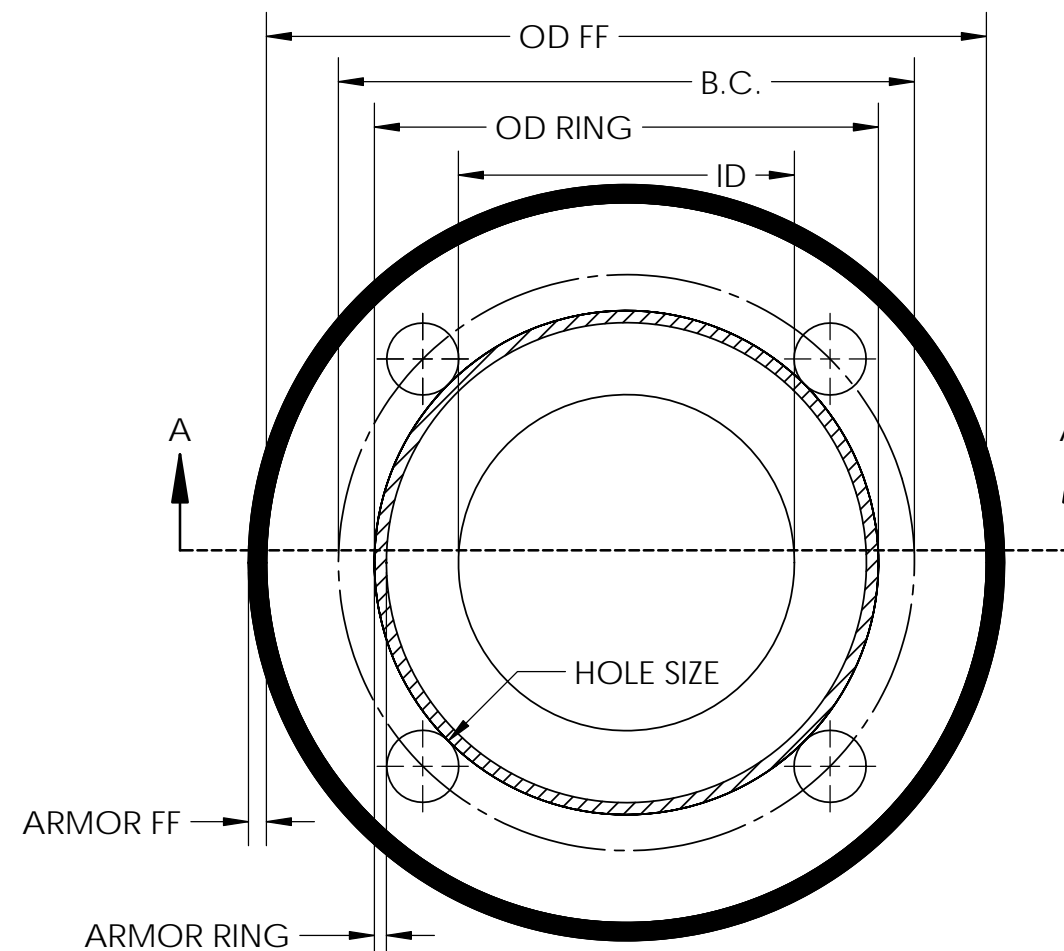

TOLERANCES UNLESS OTHERWISE SPECIFIED		REF.	MARKING DATA		 1911 JASMINE PASADENA TX, 77503 <small>THIS DRAWING, AND ALL INFORMATION CONTAINED IN IT, IS CONFIDENTIAL, PROPRIETARY, AND IS THE SOLE PROPERTY OF Vee Interests LLC AND MAY NOT BE REPRODUCED, COPIED OR DISTRIBUTED WITHOUT THE EXPRESS WRITTEN CONSENT OF Vee.</small>		
DIMENSIONS ARE IN INCHES		[1]	N/A				
ANGLES... ± 0°30'		DWN. BY: PJV					
BREAK SHARP EDGES .015 MAX.		CHK. BY:					
		APPR. BY:		PTFE SPACER DETAIL			
EST. WEIGHT: N/A		DO NOT SCALE	SCALE 1:2			SHEET 1	OF 1
REV	DATE	DESCRIPTION	DWN	APPR	SIZE B	DRAWING NO. VEE-1033	REV. 1

1	5 APR 19	ADDED #300 TABLE	PJV	
0	19 SEP 18	INITIAL RELEASE	---	---

1

2

OSI-HOU-B-R4

A

B

C

D

4/5/2019 10:07:32 AM